

Secure practically any firearm on a trunk lid

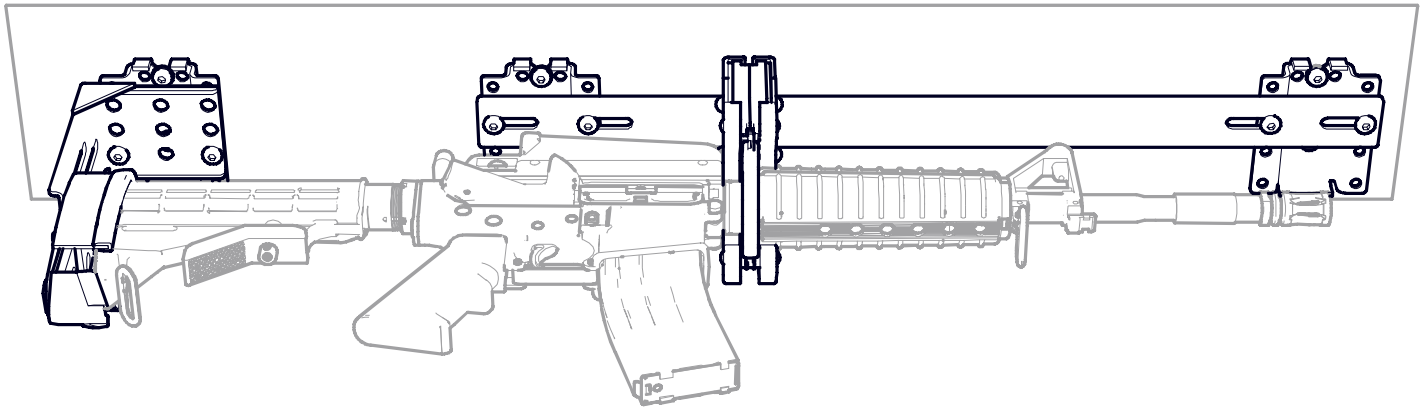

Exploded view:

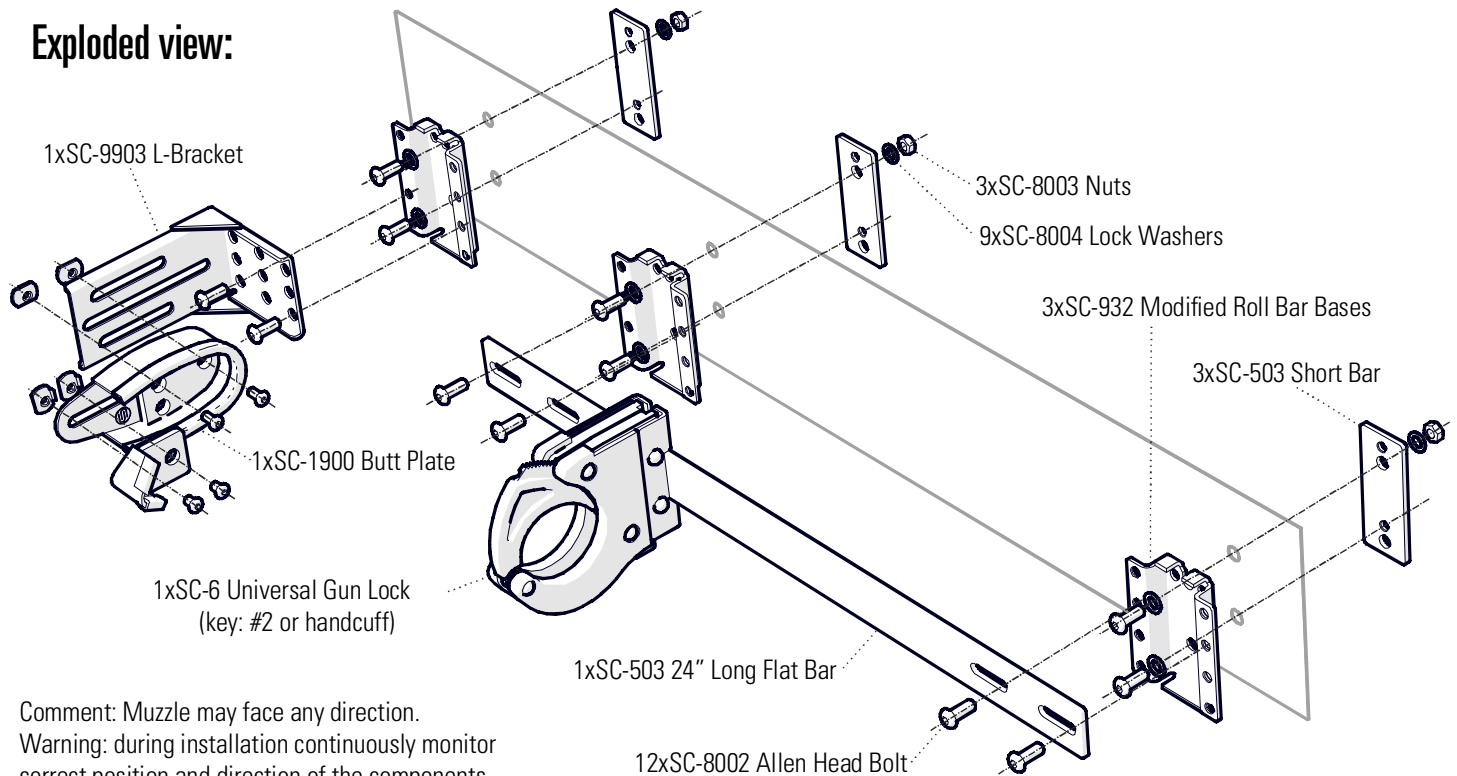

Comment: Muzzle may face any direction.
Warning: during installation continuously monitor correct position and direction of the components.

Components:

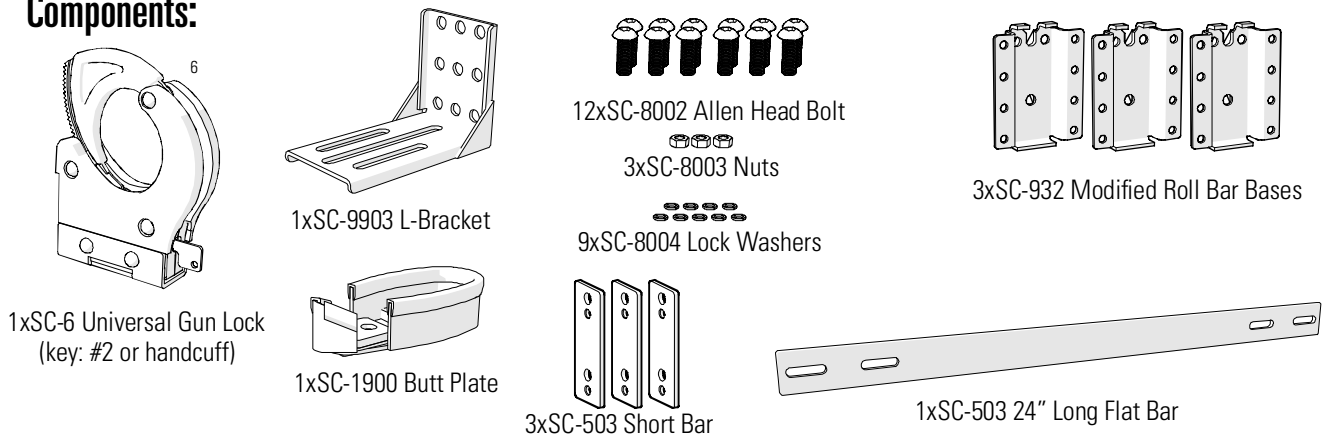

1 Install Gunlock

Install Long Flat Bar (A) (SC-503 24") onto Gunlock (SC-6), it can be secured in center position with the hidden Allan Head Bolt located on the middle of the lock; do not tighten the bolt (B) yet.

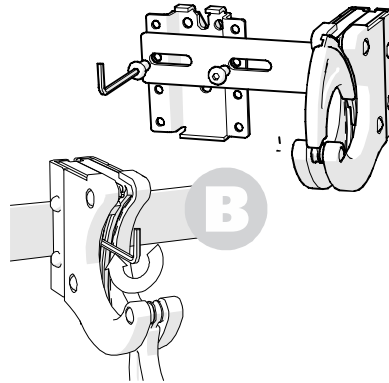
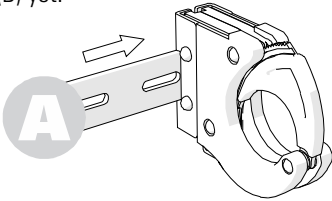

Install both ends of the Short Bar (SC-503) temporarily onto the two Modified Roll Bar Bases (SC-932).

2 Install Butt plate

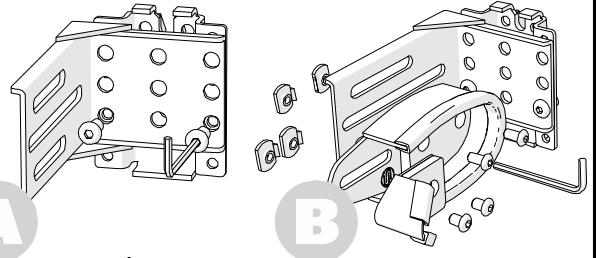

3 Adjust the parts

Slightly tighten all bolts and screws so you can still move parts around. Put your actual weapon in the gun lock and butt plate and position your complete assembly at your intended location. Adjust hinge height/angle and butt plate position until your weapon is properly lined up. If you close the ratchet arm tightly on your firearm, you will have to press or tap the outer rubber surface of the ratchet arm when deploying the firearm. Assemble the setup on the table and if the gun is in its proper position and measure the location. Keep the measurements and remove the Gunlock and the L Bracket from the 2 Bases.

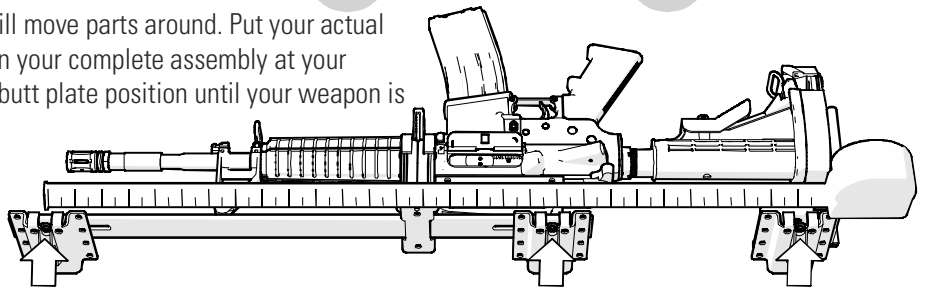

5 Install Base Plates

Apply Short Bars (SC-503) behind trunk lid rib and attach Modified Roll Base Base (SC-932).

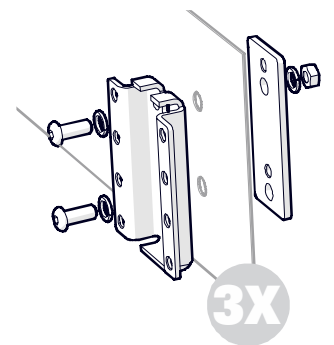

4 Mark the base

Mark the position of holes - as measured above - on the back of the partition wall pipe.

Warning: after installation the gun must have enough room under the ceiling with leaving room on both sides.

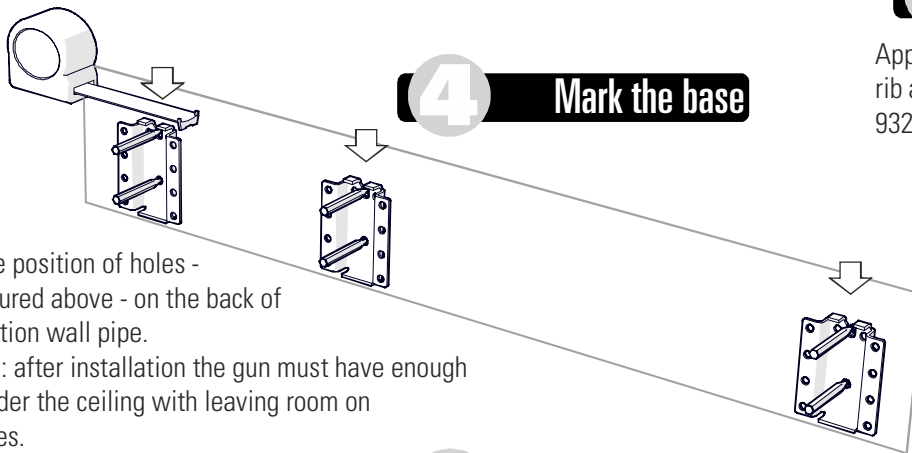

6 Assembly Elements

Install Gunlock onto Roll Bar Base (as shown in step 1) and the Long Flat Bar (as shown in step 2).

7 Tighten the Screws

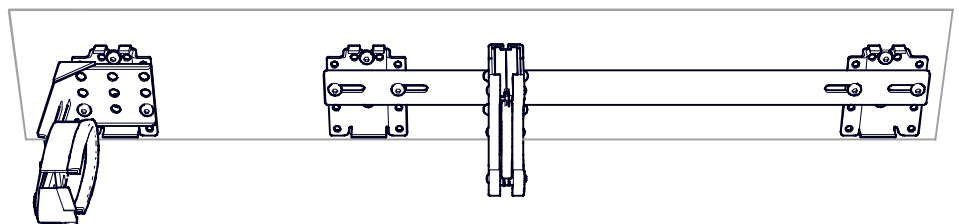

Place your weapon into the setup, test and retest your installation by repeatedly inserting and removing the weapon from the assembly. When satisfied, tighten all screws and test again.

Rapid-Adjust Universal Overhead Gun Rack with SC-6 Lock **SC-934-5-A-MTL**

Important

Should you have any problem installing or using Santa Cruz products, we are here to help you every step of the way. Just give us a call at our toll free number (800) 847-5428 and we will be glad to help you with the installation, special part request or any other way you might need assistance.

WARNING! SAFETY FIRST!
Gunlock Safety Precautions



NOTE:

Santa Cruz Gunlocks, LLC (SCG) gun racks and gunlocks are intended for temporary, secure storage of firearms. They are not substitutes for a permanent storage enclosure and only act as limited theft deterrents. And they will not prevent accidental discharge/ring of a chambered round.

To properly and safely use the SCG gun rack and/or gunlock:

- Do not use if your firearm does not fit the SCG gun rack and/or gunlock
- Never chamber a round while using a SCG gun rack and/or gunlock
- It is the responsibility of the user to operate the SCG gun rack and/or gunlock properly and safely

Santa Cruz Gunlocks, LLC (SCG) warrants this product to be free of defects in material and workmanship under normal use for one year from the date of purchase.

SCG makes no other express or implied warranties of the product. The purchaser's sole and exclusive remedy in the unlikely event of breach of warranty is expressly limited to, at SCG's election, repair, refurbishment, or replacement of the defective product with the same version or an upgrade or, if replacement is not possible, a refund of the purchase price.

Shipping cost to SCG must be paid by the user and SCG will pay return shipping charges. Repair parts and replacement products will be provided on an exchange basis only and will be either reconditioned or new. This limited warranty does not cover damage to the product resulting from accident, disaster, misuse, abuse, negligence, improper installation or modification or repair of the product other than by SCG. Limited warranty service may be obtained by returning the product to SCG. THIS LIMITED WARRANTY IS IN LIEU OF ALL OTHER WARRANTIES, EXPRESS OR IMPLIED, INCLUDING, BUT NOT LIMITED TO, THE IMPLIED WARRANTIES OF MERCHANTABILITY AND FITNESS FOR A PARTICULAR PURPOSE. Some states, do not allow the exclusion of implied warranties, so their exclusion above may not apply to you.

LIMITATION OF LIABILITY

NEITHER SCG NOR ITS AUTHORIZED DEALER(S) SHALL BE LIABLE FOR ANY DIRECT, INDIRECT, INCIDENTAL, SPECIAL, OR CONSEQUENTIAL DAMAGES, WHETHER IN AN ACTION IN CONTRACT OR TORT (INCLUDING NEGLIGENCE AND STRICT LIABILITY), SUCH AS, BUT NOT LIMITED TO, LOSS OF ANTICIPATED PROFITS OR BENEFITS RESULTING FROM THE USE OR NOT USE OF THE PRODUCT OR ANY BREACH OF ANY WARRANTY, EVEN IF SCG OR ITS AUTHORIZED REPRESENTATIVE HAS BEEN ADVISED OF THE POSSIBILITY OF SUCH DAMAGES. IN NO EVENT WILL SCG OR ITS AUTHORIZED REPRESENTATIVES' LIABILITY EXCEED THE PRICE PAID FOR THE PRODUCT.

Tamper resistant hardware (optional)



Tamper Resistant
Torx Head Bolt
5/16-18



TT-40 Torx Bit

Tools needed for installation

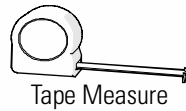

Tape Measure

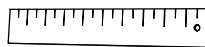

Ruler



3/16" Hex Wrench

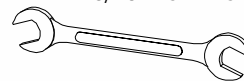

1/2" Wrench



Nutdriver



Pencil

Note: