

OTHER PRODUCTS AVAILABLE FROM SANTA CRUZ

Gunlocks:

- o Model SC-1 for pump shotguns
- o Model SC-1/AR for automatic shotguns
- o Model SC-5 Universal for any weapon

Mounting Brackets:

- o Model SC-915/BV BH Wall/Cage/Trunk
- o Model SC-931 Muzzle Down
- o Model SC-936 Universal

Accessories:

- o Solenoid (SC-1909)
- o Spare keys (specify style or number)
- o Butt Plate (SC-1900)
- o Timer (SC-7009)
- o Mounting hinge (SC-9302)

Package contents

1 X Hinge Part no. SC-9302
1 x L bracket Part no. Sc-9902
1 x Butt plate Part no. Sc-1900
(adjustable butt plate with screws) or
1 x Butt plate Part no. SC-1901
(solid aluminum butt plate with screws)
6 x 5/16 x 18 x 3/4 carriage bolts, flat washers,
lock washers

We reserve the right to change our design and prices any time without notice.

IMPORTANT

Should you have any problem installing or using Santa Cruz products, we are here to help you every step of the way.

Just give us a call at our toll free number (800) 847-5428 and we will be glad to help you with the installation, special part request or any other way you might need assistance.

LIMITED WARRANTY

Santa Cruz Gunlocks, LLC. (SCG) warrants this product to be free of defects in material and workmanship under normal use for the life of the car it was originally installed in new. SCG makes no other express or implied warranties of the product. The purchaser's sole and exclusive remedy in the unlikely event of breach of warranty is expressly limited to, at SCG's election, repair, refurbishment, or replacement of the defective product with the same version or an upgrade or, if replacement is not possible, a refund of the purchase price.

Shipping cost to SCG must be paid by the user and SCG will pay return shipping charges. Repair parts and replacement products will be provided on an exchange base only and will be either reconditioned or new. This limited warranty does not cover damage to the product resulting from accident, disaster, misuse, abuse, negligence, improper installation or modification or repair of the product other than by SCG. Limited warranty service may be obtained by returning the product to SCG at the address below.

THIS LIMITED WARRANTY IS IN LIEU OF ALL OTHER WARRANTIES, EXPRESS OR IMPLIED, INCLUDING, BUT NOT LIMITED TO, THE IMPLIED WARRANTIES OF MERCHANTABILITY AND FITNESS FOR A PARTICULAR PURPOSE. Some states, do not allow the exclusion of implied warranties, so their exclusion above may not apply to you.

LIMITATION OF LIABILITY

NEITHER SCG NOR ITS AUTHORIZED DEALER(S) SHALL BE LIABLE FOR ANY DIRECT, INDIRECT, INCIDENTAL, SPECIAL, OR CONSEQUENTIAL DAMAGES, WHETHER IN AN ACTION IN CONTRACT OR TORT (INCLUDING NEGLIGENCE AND STRICT LIABILITY), SUCH AS, BUT NOT LIMITED TO, LOSS OF ANTICIPATED PROFITS OR BENEFITS RESULTING FROM THE USE OR NOT USE OF THE PRODUCT OR ANY BREACH OF ANY WARRANTY, EVEN IF SCG OR ITS AUTHORIZED REPRESENTATIVE HAS BEEN ADVISED OF THE POSSIBILITY OF SUCH DAMAGES. IN NO EVENT WILL SCG OR ITS AUTHORIZED REPRESENTATIVES' LIABILITY EXCEED THE PRICE PAID FOR THE PRODUCT.

SANTA CRUZ GUNLOCKS, LLC.

450 Tyler Rd.

Webster, NH 03303

Phone: (603)746-7740 Fax: (603)746-7764

1-800-847-5428

E-mail: info@SantaCruzGunlocks.com

www.SantaCruzGunlocks.com



Wall/Trunk Bracket Model SC-916

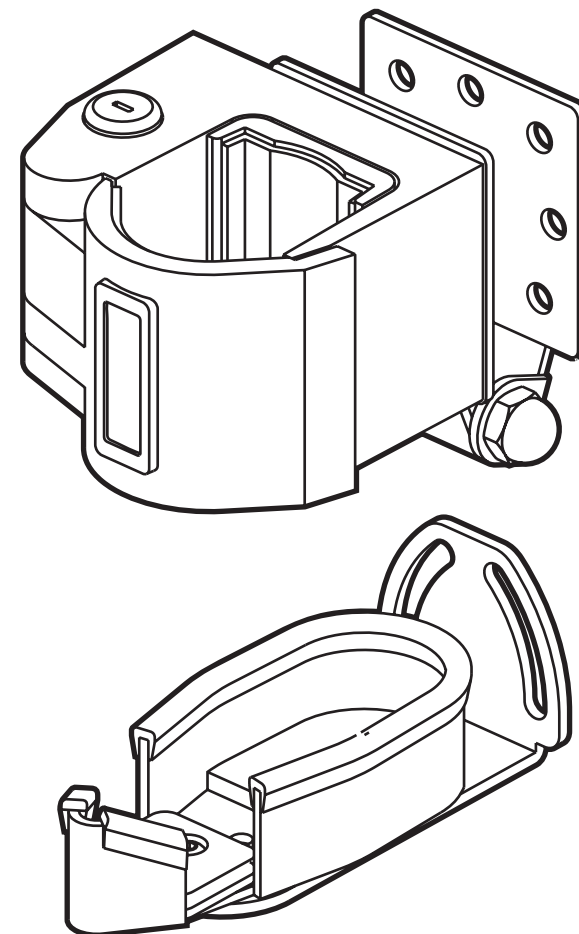

Santa Cruz Wall Brackets are designed to be mounted on a wall in vertical or horizontal position.

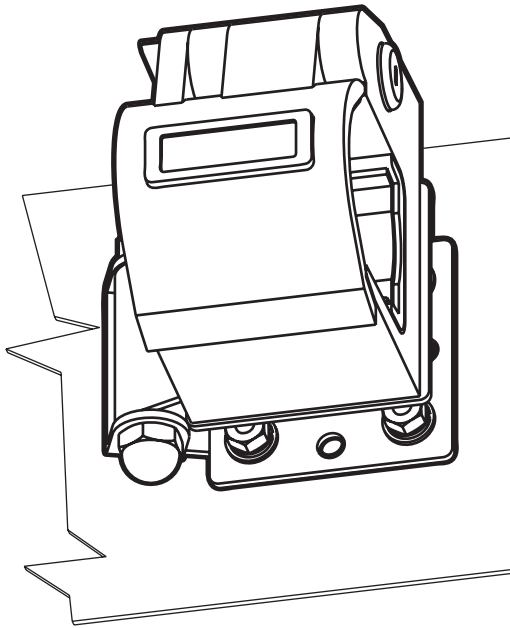
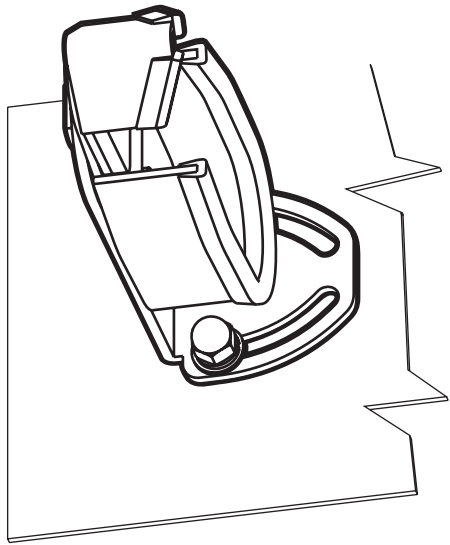

SC-916/BH

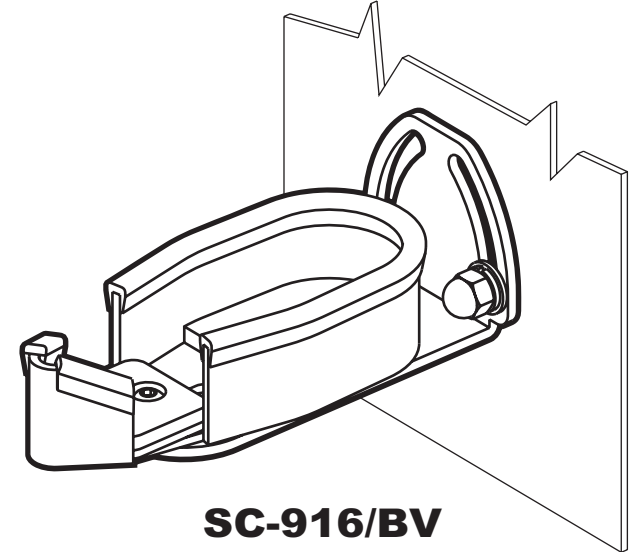
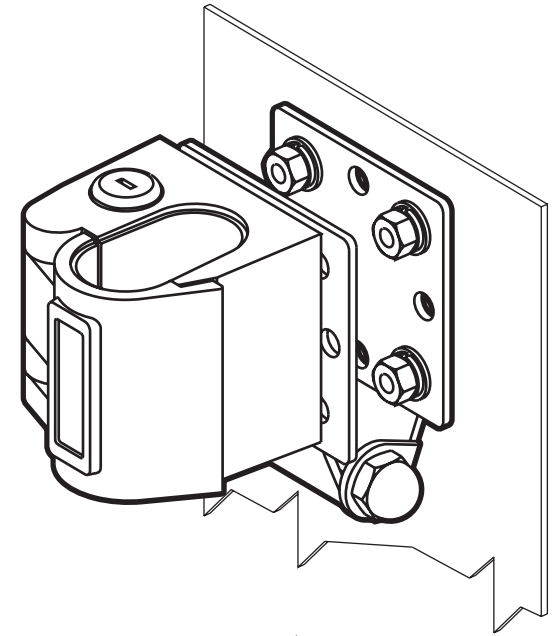

SC-916/BV

Installation:

Step 1. Install gunlock (purchased separately) on one leaf of the hinge (part no. SC-9302) with screws provided with the gunlock.

Step 2. Install butt plate on L bracket (part no. SC-9902) with allen screws that came with the butt plate.

Note: Depending on your install location, you may use only the 3 sheetmetal screws for the butt plate. You can install the butt plate directly on the wall or floor without using the L bracket.

Step 3. Slightly tighten all bolts and screws so you can still move parts around. Put your actual weapon in the gun lock and butt plate and position your whole assembly at your intended location. Adjust hinge height/angle and butt plate position until your weapon is properly lined up.

Important: Weapon must have some (1/16") free play in gun lock for gun lock mechanism to operate correctly. Weapon should not press against gun lock door.

Step 4. Mark screw locations on wall/floor. Check back side of wall for fuel or electric lines. Drill your holes and install assembly.

Step 5. Place your weapon in the setup, test and retest your installation by repeatedly installing and removing the weapon to and from the assembly. When satisfied, tighten all screws and test again.